

P610 SERIES PLANETARY AXLES

PARTS BOOK

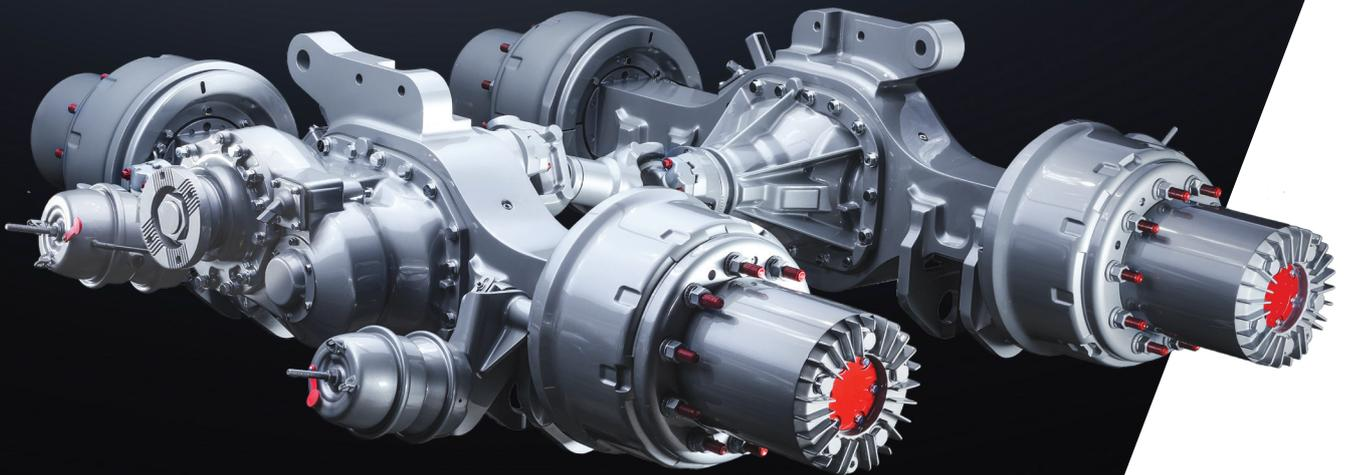

Meritor

**FOR
A WORLD
THAT'S
ALWAYS ON™**

P610 Series Planetary Axles

This parts book contains illustrated parts diagrams for the Meritor P610 tandem axle sold into the Australian region. This tandem axle features a five planetary gear wheel end reduction and is designed to meet the demands of heavy-duty applications in this region.

For maintenance and servicing information please also refer to the following documents.

Maintenance Manual: MM-11118

Front Carrier: MM-0194

Rear Carrier: MM-01105

Wheel end Maintenance Manual: MM-1189

These can be found at the following website:

www.cummins.com/components/drivetrain-systems/literature-on-demand

Please note that service and parts information for P600 series axles sold into regions other than Australia may differ from the information found in this manual. If you have any questions or concerns please contact your local Meritor Australia Customer Service representative:

Cummins-Meritor Aftermarket

50 Calarco Drive
Derrimut, Victoria 3026
Australia

Email: cvaau.sales@meritor.com
Phone: (+613) 8353 6050

Warranty

Meritor Australia new parts are warranted for one-year/unlimited kilometers (unless otherwise stated on the part or within Meritor literature) from date of installation. This warranty covers against defective material or workmanship (but not against damage caused by accident, abuse, improper installation, maintenance or repair) of the parts where parts are used on vehicles meeting the required specifications for the replacement part.

For details regarding the Cummins Meritor Australia Warranty terms and conditions or to submit a warranty claim form please contact Cummins Meritor Aftermarket Customer Service agent on (03) 8353 6050 or visit www.meritorpartsxpress.com

Table of Contents

P610 Series Planetary Axles

Meritor planetary drive axles are engineered and manufactured to deliver higher capacity and improved performance across a multitude of heavy-duty off-highway applications.

Meritor planetary axles are known for exceptional quality, strength and toughness, and each axle is backed by an intensive validation process at our global design and testing centers.

P610 Series Planetary Axles - Table of Contents

Warranty	2
Forward Housing and Carrier	4-5
Forward Carrier Assembly	6-8
Forward Carrer Housing	9-9
Rear Housing and Carrier	10-11
Rear Carrier Assembly	12-13
Rear Carrier Housing	14-14
Brake Assembly	15-16
Hub and Drum Assembly	17-17
Planetary Case Assembly	18-19
Spindle Assembly	20-21
Gearsets and Bearing Kits	22-23

Forward Housing and Carrier

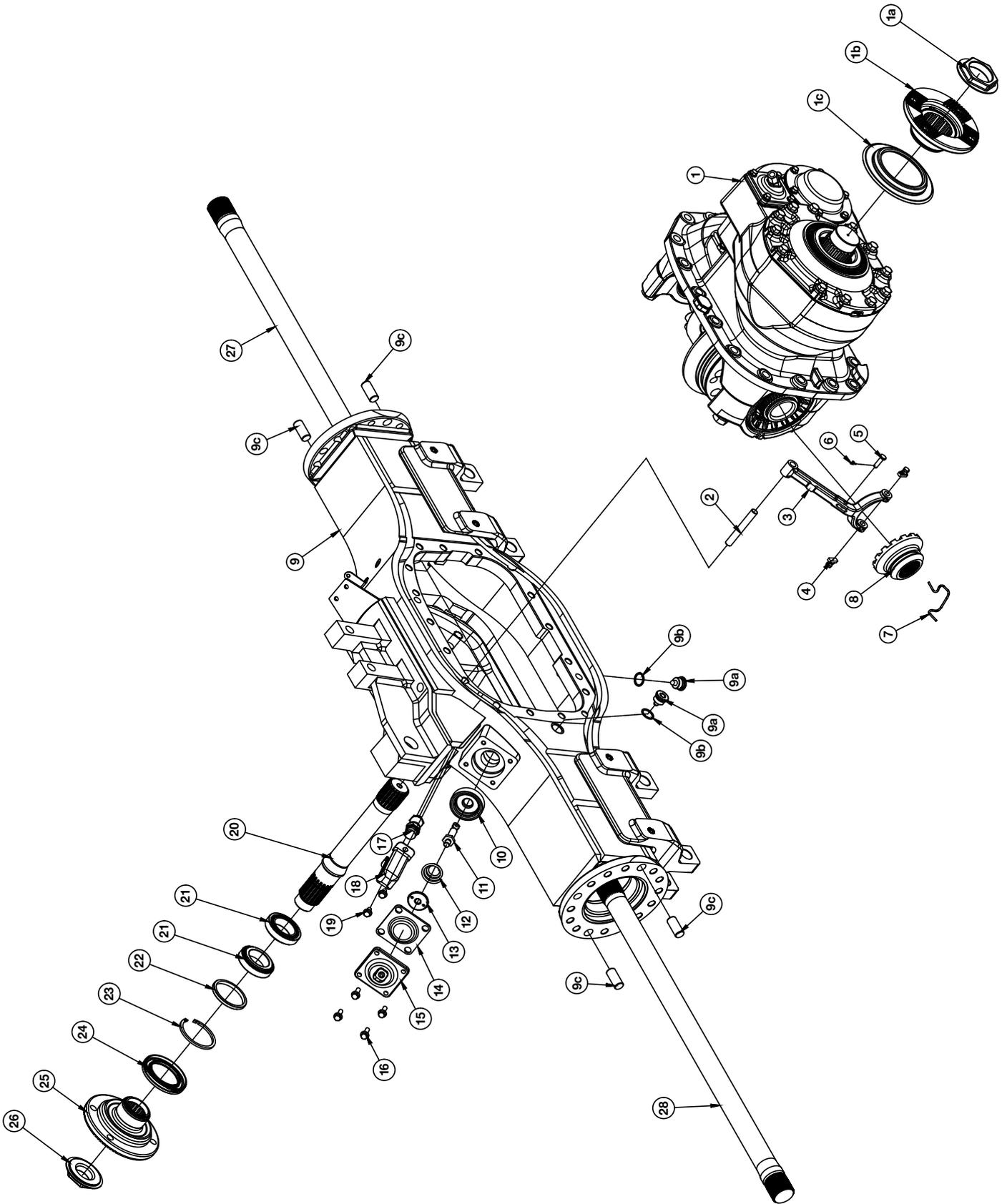

Forward Housing and Carrier

Item	Description	Quantity	Part Number	Notes
1	Carrier DT100H	1	A 4 3200S2411(XXX)	(XXX) refers to ratio
1a	Nut-Lock,Fin.	1	8171338	
1b	Flange-Companion,Fin.	1	3260V2024	
1c	Shield	1	3264M1495	
2	Shift Rail Diff	1	3152043	Carrier DCDL Kit MERKIT008CAR
3	Yoke Shift, Diff	1	1069372	
4	Spindle DCDL EV71	2	1523087	
5	Capscrew EV71	1	964845	
6	Pin Scissors EV71	1	907822	
7	Lock Loop DCDL EV71	1	1523084	
8	Clutch Collar DCDL EV71	1	1522354	
9	Housing Assembly	1	C 4 3801P1784	
9	Housing Assembly	1	C 5 3801P1784	KW6-60-Suspension (Refer BOM for suspension brackets)
9a	Gasket Copper	2	949329	
9b	Plug Drain Magnetic	2	981281	
9c	Dowel 20mm Dia,45mm Long	4	1246T1268	
10	Diaphragm Seat Main Diff	1	3261S1085	Housing DCDL Kit MERKIT009CAR
11	Rod Push	1	2244C1277	
12	Spring DCDL	1	3152042	
13	Sleeve Diaphragm	1	3152044	
14	Diaphragm	1	2297A8477	
15	Cover	1	3266V1504	
16	Screw M8x25x1.25	4	945444	
17	Switch Assy DCDL N/C	1	2237L1390	
18	Bracket-Protector	1	3155P1472	
19	Screw M8x16x1.25	2	10X1783	
20	Shaft Output	1	3297C1797	
21	Bearing Roller	2	1524988	
22	Spacer	1	2803N3524	
23	Kit Snap Ring Thru Shaft	1	KIT 576	
24	Seal Thru Shaft	1	1524838	
25	Flange Companion FUO	1	3260C2057	
26	Nut Thru Shaft	1	1673393	
27	LH Axle Shaft FE1022MM	1	3802S2151	LH
28	RH Axle Shaft FE1140 D1.77"	1	3802T2152	RH

Forward Carrier Assembly

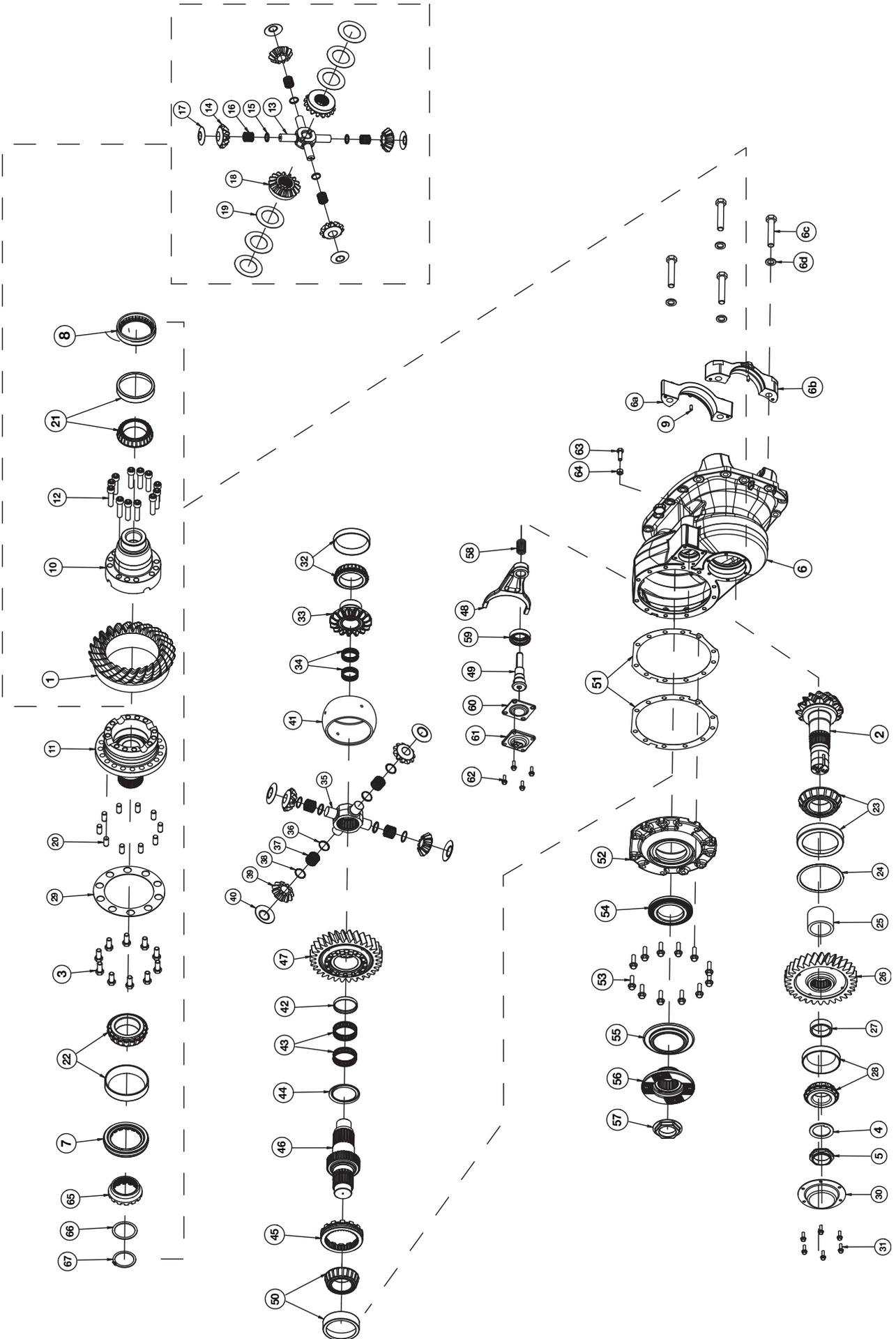

Forward Carrier Assembly

Item	Description	Quantity	Part Number	Notes
1	Crown Wheel	1	-	Refer to chart on page 22 for complete range of gearsets and kits.
2	Pinion	1	-	
3	Screw	10	963311	
4	Thrust Washer	1	948650	
5	Nut	1	1522293	
6	Diff. Carrier Housing	1	A2 3200S2411	Carrier Housing Kit MERKIT010CAR
6a	Diff. Bearing Cap Gear Side	1	Refer item 6	
6b	Diff. Diff. Bearing Cap Pinion Side	1	Refer item 6	
6c	Cap Screw	4	MS220110P2	
6d	Washer Cap Screw	4	42X1021	
7	Adjusting Ring - RH	1	1673664	
8	Adjusting Ring - LH	1	1673663	
9	Set Screw	2	1069782	
10	Diff. Housing, Left	1	1524855	For ratios 1.09 to 1.19
10	Diff. Housing, Left	1	1524854	E710.M Diff Case Kit 1.32 - 2.08
11	Diff. Housing, Right	1	1524856	
12	Hex. Socket Screw	12	959281	
13	Spider	1	1522343	273933 Diff Nest Kit
14	Diff. Pinion	4	2233H1178	
15	Spacer Plate	4	1522344	
16	Needle	140	1522345	
17	Thrust Washer	4	1522347	
18	Diff. Side Gear	2	2234L1364	
19	Thrust Washer	6	1524716	
20	Pin	10	1246X1298	For ratio 1.32 - 2.08
21	Roller Bearing LH	1	1524964	
22	Roller Bearing RH	1	1524857	
23	Pinion Bearing	1	1524982	
24	Shim Kit	1	E888.M	Use as required
25	Spacer Sleeve W=63.3	1	1524870	
25	Spacer Sleeve W=62.8	1	1524996	
25	Spacer Sleeve W=62.3	1	1524997	
26	Gear	1	1524953	
27	Spacer Sleeve	1	E966.M	Spacer Kit. Use as required
28	Pinion Bearing	1	1524985	
29	Lock Plate	1	1524861	
30	Cover	1	3266R1682	
31	Flange Screw	6	945444	
32	Roller Bearing	1	1524061	

Forward Carrier Assembly

Item	Description	Quantity	Part Number	Notes
33	Diff. Gear	1	1524889	
34	Needle Roller Assy	1	181632	
35	Spider	1	1524883	E876.M Differential pinion set
36	Spacer Plate	4	1524884	
37	Needle	184	1522345	
38	Spacer Ring	4	1524885	
39	Diff. Pinion	4	1524886	
40	Thrust Washer	4	1229F4920	
41	Carrier	1	1524888	
42	Spacer Sleeve	1	1524882	
43	Needle Roller Assy	1	1524881	
44	Washer	1	1229A5253	
45	Engaging Sleeve	1	3107C1251	E673.M Interaxle differential lock kit
46	Input Shaft	1	3297C1485	
47	Gear Helical	1	3892W5743	
48	Shift Yoke	1	3296R1318	
49	Piston	1	2244K1207	
50	Roller Bearing	1	1524058	
51	Shim	-	E647.M	Use as required.
52	Bearing Sleeve	1	3226P1628	
53	Flange Screw	12	965192	
54	Oil Seal Assy	1	A1 1205L2794	E878.M Kit for input flange
55	Shield	1	3264M1495	
56	Companion Flange	1	3260V2024	
57	Lock Nut	1	8171338	
58	Spring	1	1524891	
59	Diaphragm Seat	1	3261T1086	
60	Diaphragm	1	2297A8477	
61	Cover	1	3266V1504	
62	Flange Screw	4	945444	
63	IAD Adjustment Screw	1	41X1585	
64	Nut	1	MN-312-1	
65	Fixed collar	1	1522353	
66	Spacer ring	1	1522355	
67	Circlip	1	914480	

Forward Carrier Housing

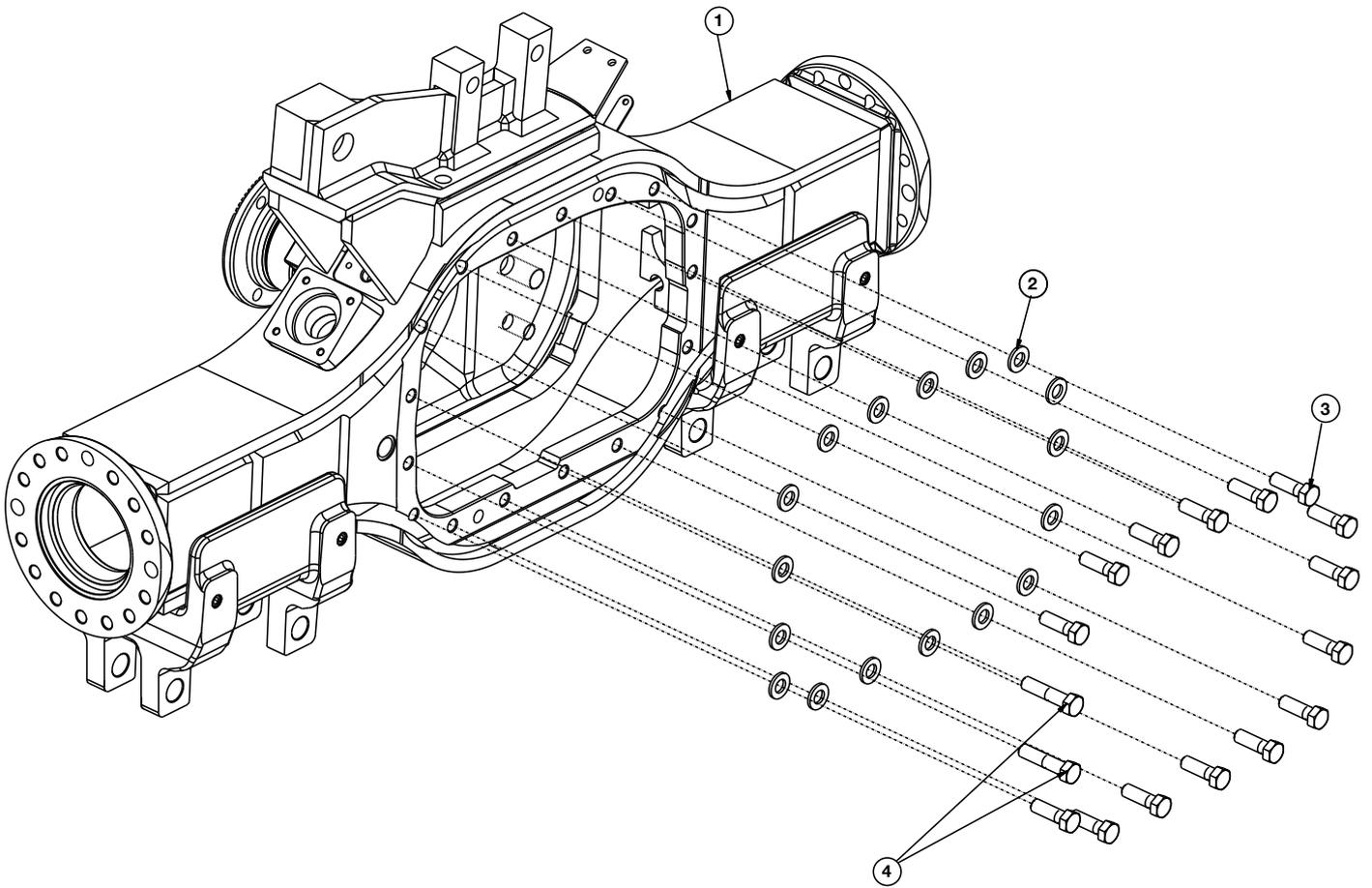

Item	Description	Quantity	Part Number	Notes
1	Housing Assembly	1	C 4 3801P1784	Neway Suspension
1	Housing Assembly	1	C 5 3801P1784	KW6-60 Suspension
2	Washer Flat M16x3.5	17	MWA 516	
3	Screw M16x50x2 GRD10.9	15	MS216050N 2	
4	Screw M16x70x2 GRD10.9	2	MS216070N 2	

FORWARD CARRIER ASSEMBLY

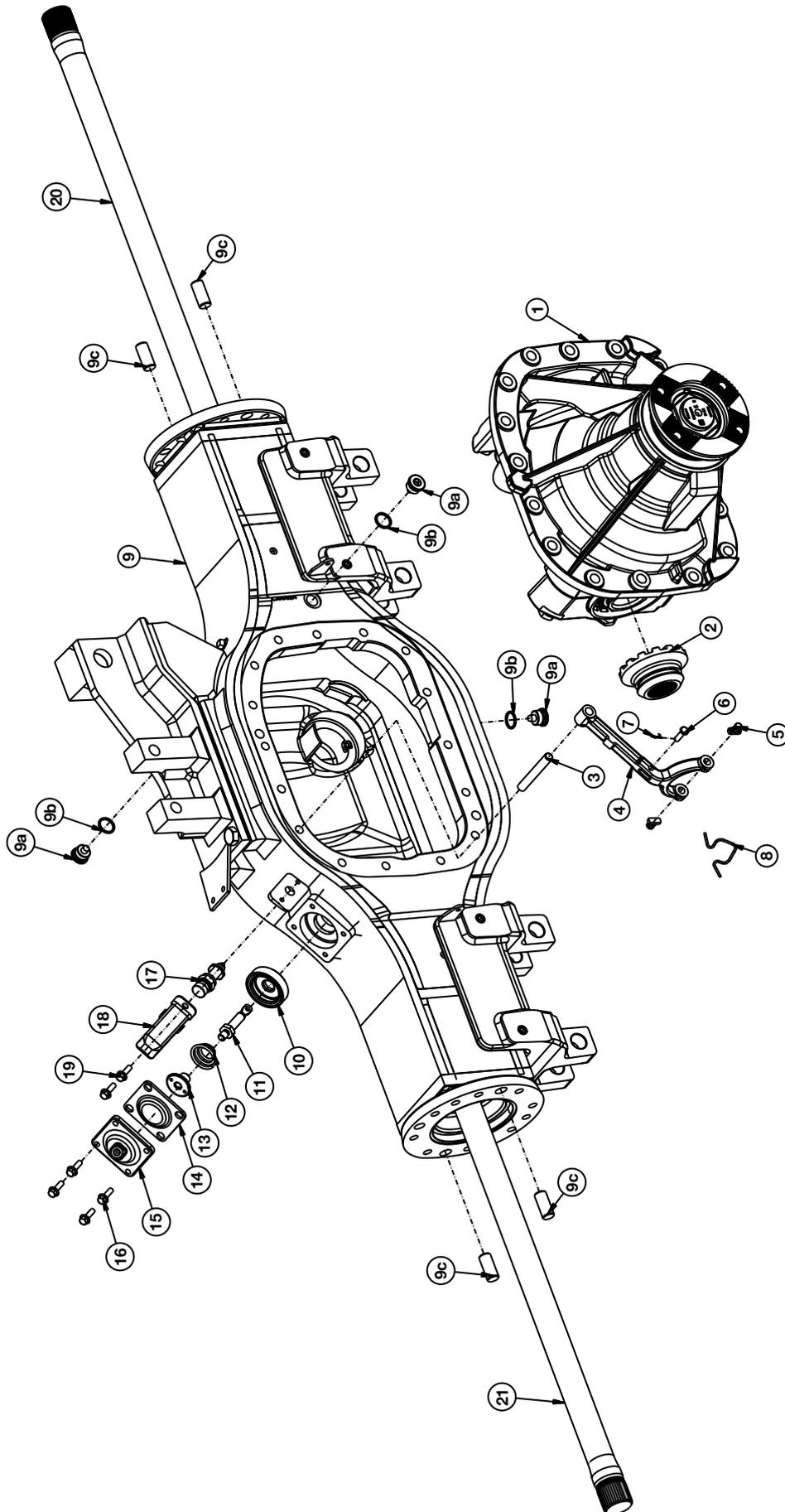

FORWARD CARRIER ASSEMBLY

Item	Description	Quantity	Part Number	Notes
1	Carrier DS70H	1	A3 3200W2415 (XXX)	(XXX) refers to ratio.
2	Clutch Collar DCDL EV71	1	1522354	DCDL Kit (Carrier Kit) MERKIT008CAR
3	Shift Rail Diff	1	3152043	
4	Yoke Shift, Diff	1	1069372	
5	Spindle DCDL EV71	2	1523087	
6	Capscrew EV71	1	964845	
7	Pin Scissors EV71	1	907822	
8	Lock Loop DCDL EV71	1	1523084	
9	Housing Assembly	1	C 5 3801N1782	
9	Housing Assembly	1	C 6 3801N1782	KW6-60 SUSPENSION - Includes 9a, 9b and 9c
9a	Plug Drain Magnetic	3	A 1250N1496	
9b	Gasket Copper	3	949329	
9c	Dowel 20mm Dia,45mm Long	4	1246T1268	
10	Diaphragm Seat Main Diff	1	3261S1085	DCDL Air Cylinder Kit (Housing Kit) MERKIT009CAR
11	Rod Push	1	2244C1277	
12	Spring DCDL	1	3152042	
13	Sleeve Diaphragm	1	3152044	
14	Diaphragm	1	2297A8477	
15	Cover	1	3266V1504	
16	Screw M8x25x1.25	4	945444	
17	Switch Assy DCDL N/C	1	2237L1390	
18	Bracket-Protector	1	3155P1472	
19	Screw M8x16x1.25	2	10X1783	
20	Axle Shaft LH FE1060mm	1	3802V2154	LH
21	Axle Shaft RH FE1102 D1.77"	1	3802U2153	RH

Rear Carrier Assembly

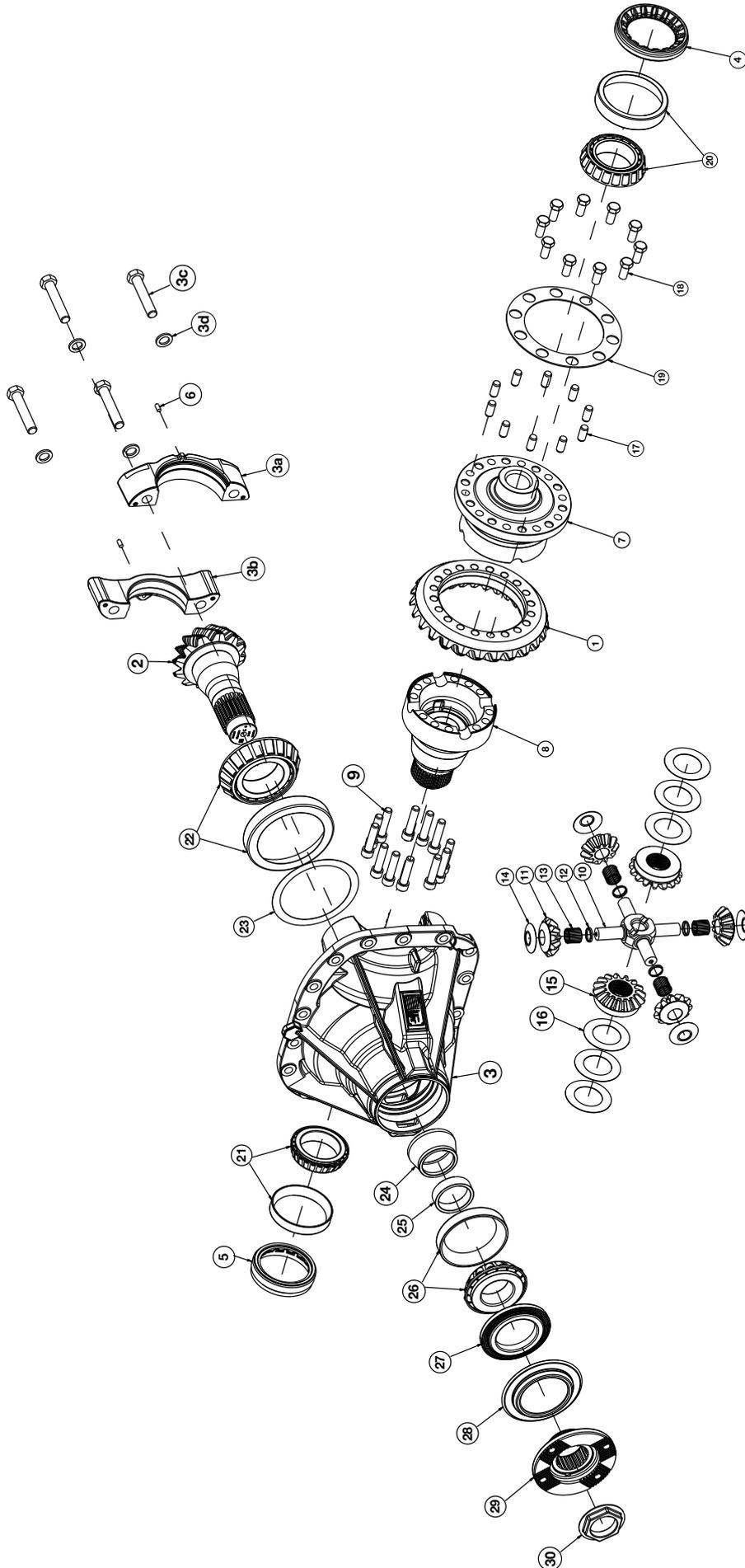

Rear Carrier Assembly

Item	Description	Quantity	Part Number	Notes
1	Crown Wheel	1	-	(Refer to gearset chart on page 22)
2	Pinion	1	-	
3	Diff. Carrier Housing Assembly	1	A2-3200-W-2415	Carrier Housing Kit MERKIT011CAR
3a	Cap-Diff. Brg Fin Gear Side	1	Refer item 3	
3b	Cap-Diff. Brg Fin Pinion Side	1	Refer item 3	
3c	Cap Screw	4	MS220110P2	
3d	Washer Cap Screw	4	42X1021	
4	Adjusting Screw	1	1673664	
5	Adjusting Screw	1	1673663	
6	Set Screw	2	1069782	
7	Diff. Housing, Left	1	1524914	For ratios 1.09 to 1.19
7	Diff. Housing, Left	1	1524915	E712.M Diff Case Kit 1.32 - 2.08 - MT610
8	Diff. Housing, Right	1	1522259	
9	Hex. Socket Screw	12	959281	
10	Spider	1	1522343	273933 Diff Nest Kit
11	Diff. Pinion	4	2233H1178	
12	Spacer Plate	4	1522344	
13	Needle	140	1522345	
14	Thrust Washer	4	1522347	
15	Diff. Side Gear	2	2234L1364	
16	Thrust Washer	6	1524716	
17	Pin	10	1246W1297	For ratios 1.32 - 2.08
18	Screw	10	963311	For ratios 1.32 - 2.08
18	Screw	10	963310	For ratios 1.00 - 1.19
19	Lock Plate	1	1524861	
20	Roller Bearing	1	1524857	
21	Roller Bearing	1	1524964	
22	Pinion Bearing	1	1524926	
23	Shim Kit	1	E964.M	Use as required
24	Spacer Sleeve Kit	1	E965.M	Use as required
25	Spacer Sleeve	1	-	E982.M Spacer Sleeve Kit
26	Pinion Bearing	1	1673537	
27	Seal	1	A1 1205L2794	
28	Shield	1	3264M1495	
29	Companion Flange	1	3260X2026	
30	Lock Nut	1	8171338	

Rear Carrier Housing

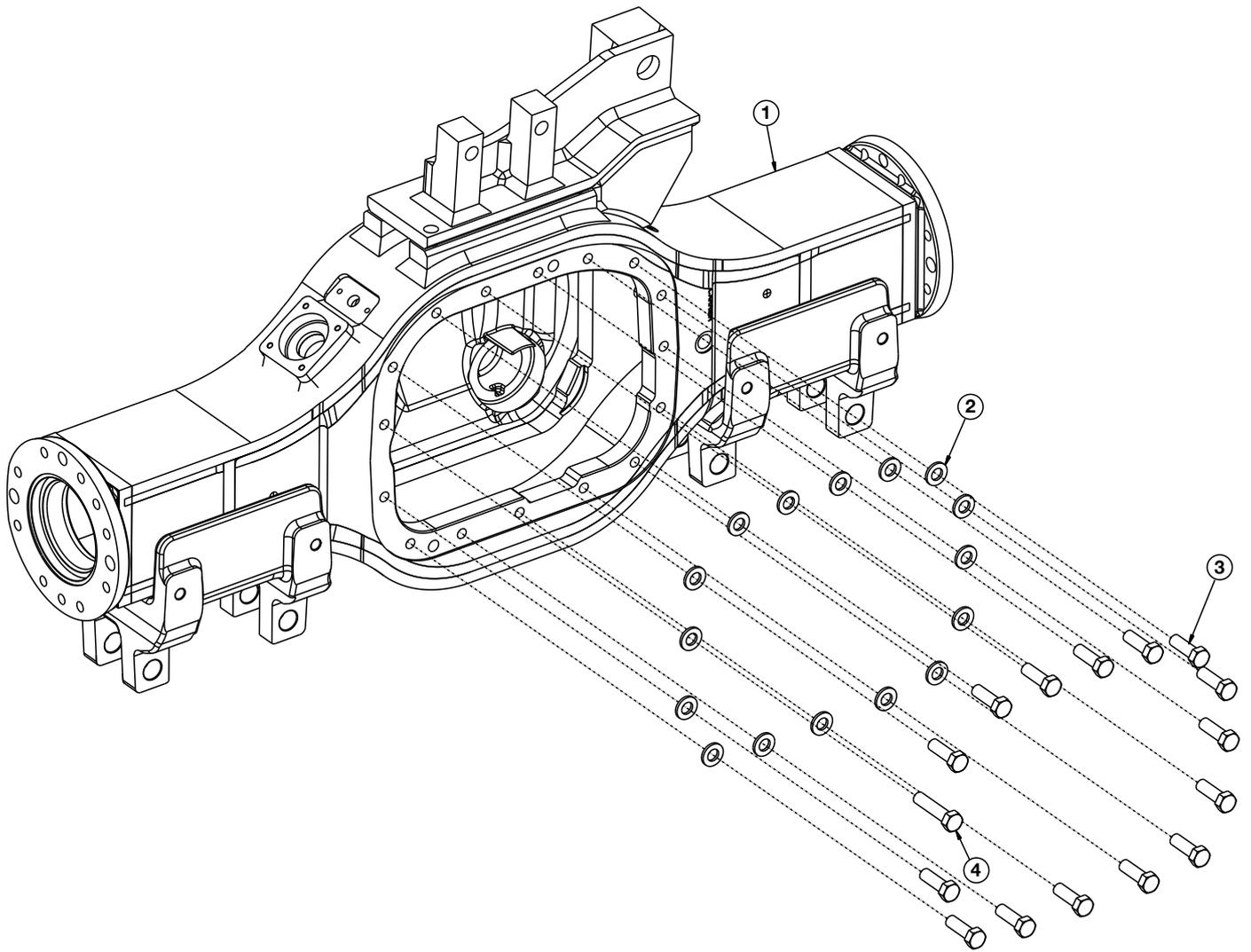

Item	Description	Quantity	Part Number	Notes
1	Housing Assembly	1	C 5 3801N1782	Neway suspension
1	Housing Assembly	1	C 6 3801N1782	KW6-60 Neway suspension
2	Washer Flat M16x3.5	16	MWA 516	
3	Screw M16x50x2 GRD10.9	15	MS216050N 2	
4	Screw M16x70x2 GRD10.9	1	MS216070N 2	

Brake Assembly

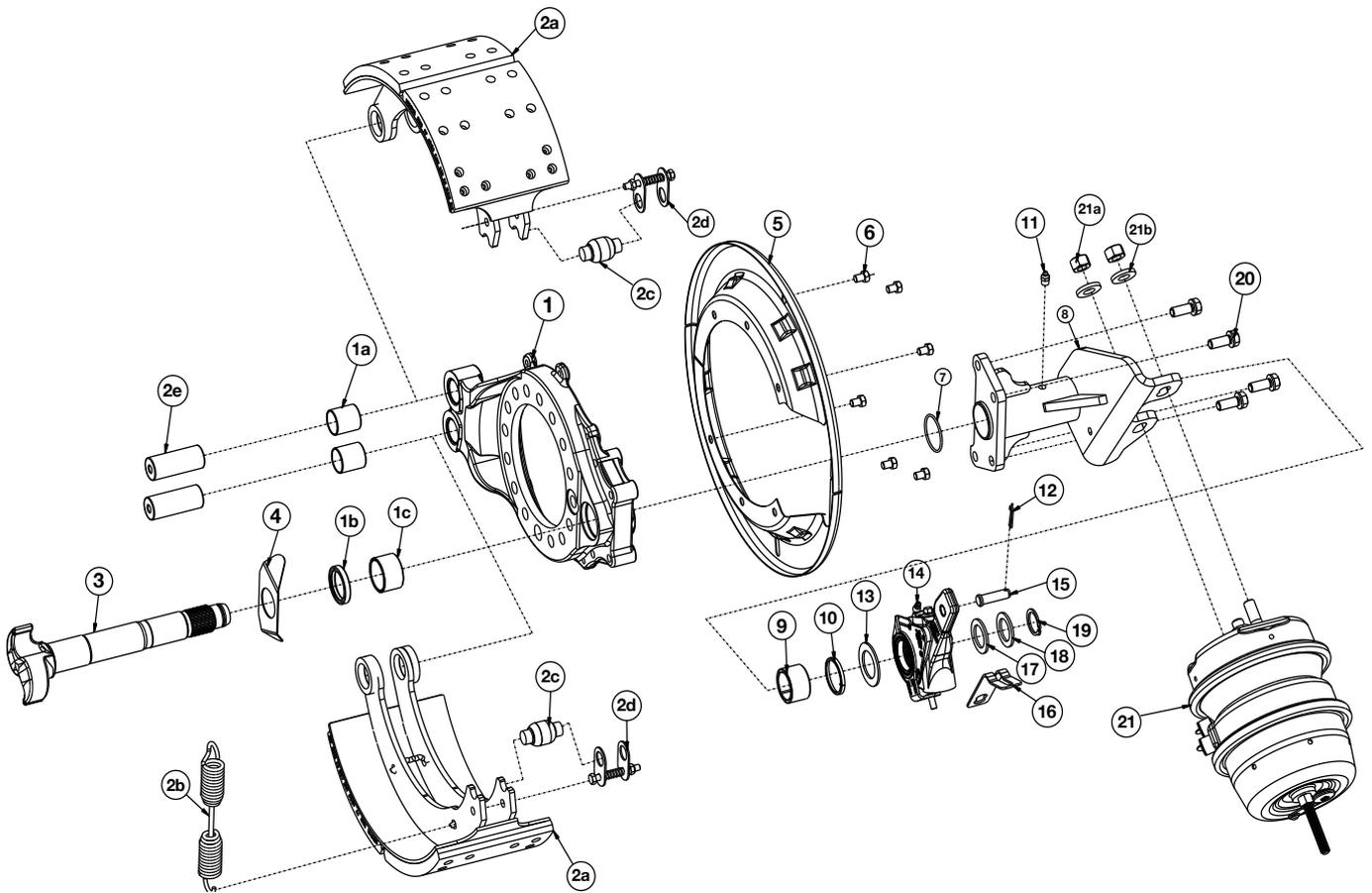

Item	Description	Quantity	Part Number	Notes
0	Brake Assembly	1	BGX 1657 6474	Forward RH KW6-60 Suspension
0	Brake Assembly	1	BGX 1657 6473	Forward LH KW6-60 Suspension
0	Brake Assembly	1	BGX 1657 6478	Forward & Rear RH Neway Suspension
0	Brake Assembly	1	BGX 1657 6477	Forward & Rear LH Neway Suspension
0	Brake Assembly	1	BGX 1657 6476	Rear RH KW6-60 Suspension
0	Brake Assembly	1	BGX 1657 6475	Rear LH KW6-60 Suspension
1	Spider Assembly Brake	1	A 5 3211K7863	Forward/Rear LH -Neway Suspension Forward LH- KW6-60 Suspension
1	Spider Assembly Brake	1	A 5 3211L7864	Forward/Rear RH -Neway Suspension Forward RH- KW6-60 Suspension
1	Spider Assembly Brake	1	A 5 3211U7873	Rear - LH KW6-60 Suspension

Brake Assembly

Item	Description	Quantity	Part Number	Notes
1	Spider Assembly Brake	1	A 5 3211T7872	Rear - RH KW6-60 Suspension
1a	Anchor Pin Bushing	2	1225B496	
1b	Seal Assy Oil	1	A 1205X2650	
1c	Bushing Cam	1	1225J1362	
2a	Shoe & Lining Assembly	2	A 7 3222R1916	Brake Shoe Kit KSMA23014515PUHD
2b	Spring Return	1	2258W 803	
2c	Roller Std Unit Pack 10	2	2297T7222	
2d	Retainer Roller	2	A 1199U 99A	
2e	Pin Assembly Anchor	2	A 1259D4A	
3	Camshaft	1	2210Q9169	Forward/Rear LH-Neway
3	Camshaft	1	2210P9168	Forward/Rear-RH-Neway
3	Camshaft	1	2210N9114	Forward-LH-KW6-60 Suspension
3	Camshaft	1	2210M9113	Forward-RH-KW6-60 Suspension
3	Camshaft	1	2210K9111	Rear LH-KW6-60 Suspension
3	Camshaft	1	2210L9112	Rear RH-KW6-60 Suspension
4	Washer Special	1	1229F4686	
5	Dust Shield	1	A1 3236Q2123	
6	Screw 3/8x0.5x16 Grd5	6	S 264B	
7	O Ring Brake Bkt 2 Spid	1	1205G 761	
8	Bracket Brake Chamber	1	L47 3299R1552	Forward/Rear LH -Neway Suspension
8	Bracket Brake Chamber	1	L47 3299S1553	Forward/Rear RH -Neway Suspension
8	Bracket Brake Chamber	1	W98 3299Q6257	Forward RH -KW6-60 Suspension
8	Bracket Brake Chamber	1	W98 3299P6256	Forward LH -KW6-60 Suspension
9	Cam Bush	1	1225H1568	
10	Grease Seal	1	A 1205V1556	
11	Fitting Grease Straight	1	1199N1860	
12	Clip-Large	1	2257D1174	
13	Washer Flat Brake Camsh	1	1229H4090	
14	Haldex Auto Slack 5.5"	1	A42 3275S1059	
15	Pin Clevis Unit Pack 20	1	19X1084	
16	Strap Assembly	1	A 2255B1250	
17	Washer 1.88 OD, 1.26 ID	2	1229J3130	Use as required
18	Washer 1.88 OD, 1.26 ID	2	1229W3117	Use as required
19	Ring Snap Unit Pack 50	1	1229D2942	
20	Bolt Assy 0.5x1.32x13	4	A 2297U9251	
21	Chamber Assy 30/30	1	D90 3276D 30	LH Side
21	Chamber Assy 30/30	1	D91 3276D 30	RH Side
21a	Nut	2	N-310-1	
21b	Flat Washer	2	1229N1626	

Hub and Drum Assembly

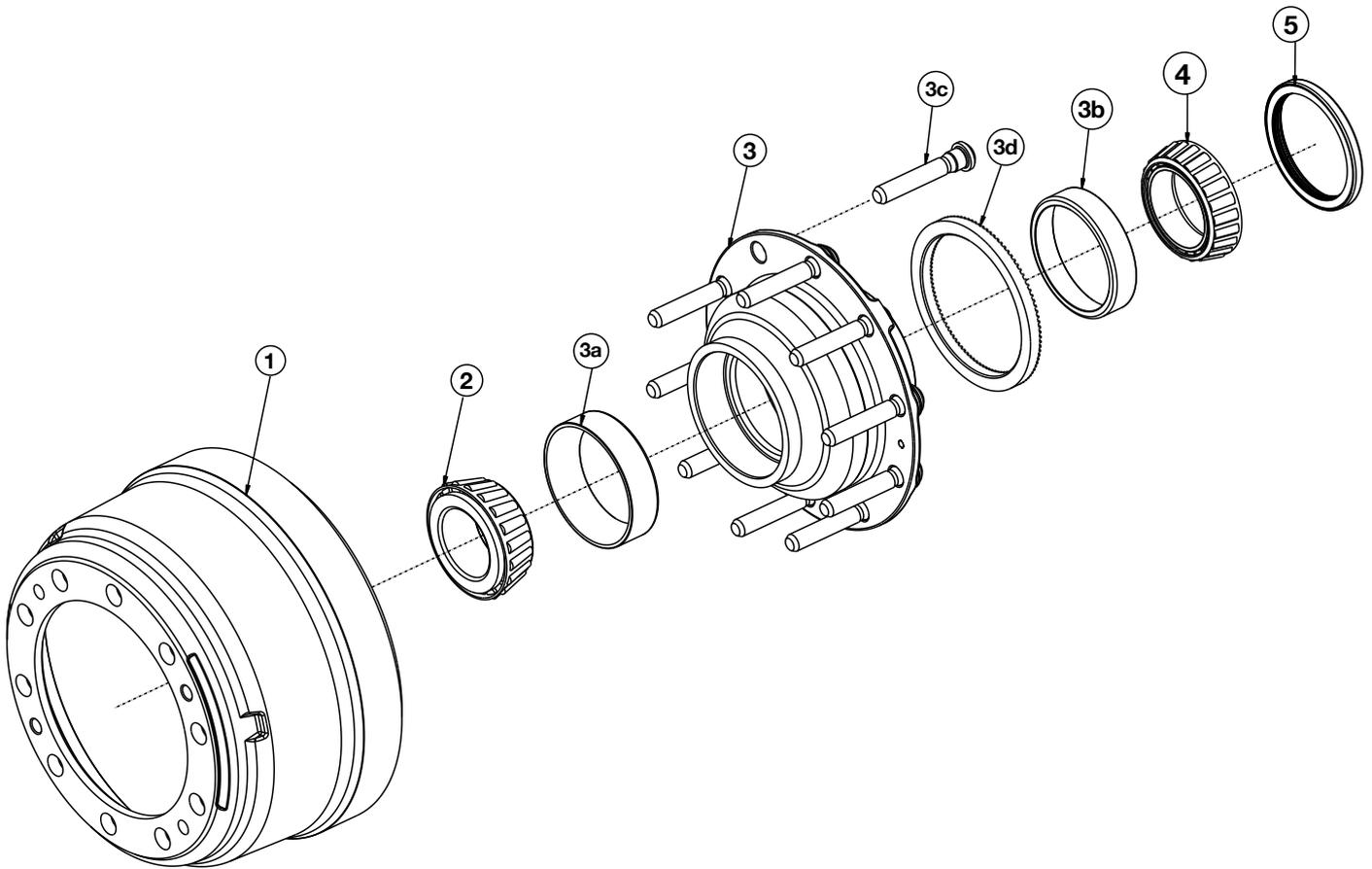

Item	Description	Quantity	Part Number	Notes
1	Drum Brake	1	03 123802	
2	Cone Bearing	1	6580	
3	Hub, Cup, Stud & PR Assy	1	B 2 333Z4602	Includes 3a, 3b, 3c and 3d
3a	Bearing Cup	1	6535	
3b	Bearing Cup	1	HM220110	
3c	Stud M22x138x1.5	10	20X2606	
3d	Pole Ring	1	3237R1318	
4	Cone Bearing	1	HM220149	
5	Hub Seal	1	A 1205P2798	

Planetary Case Assembly

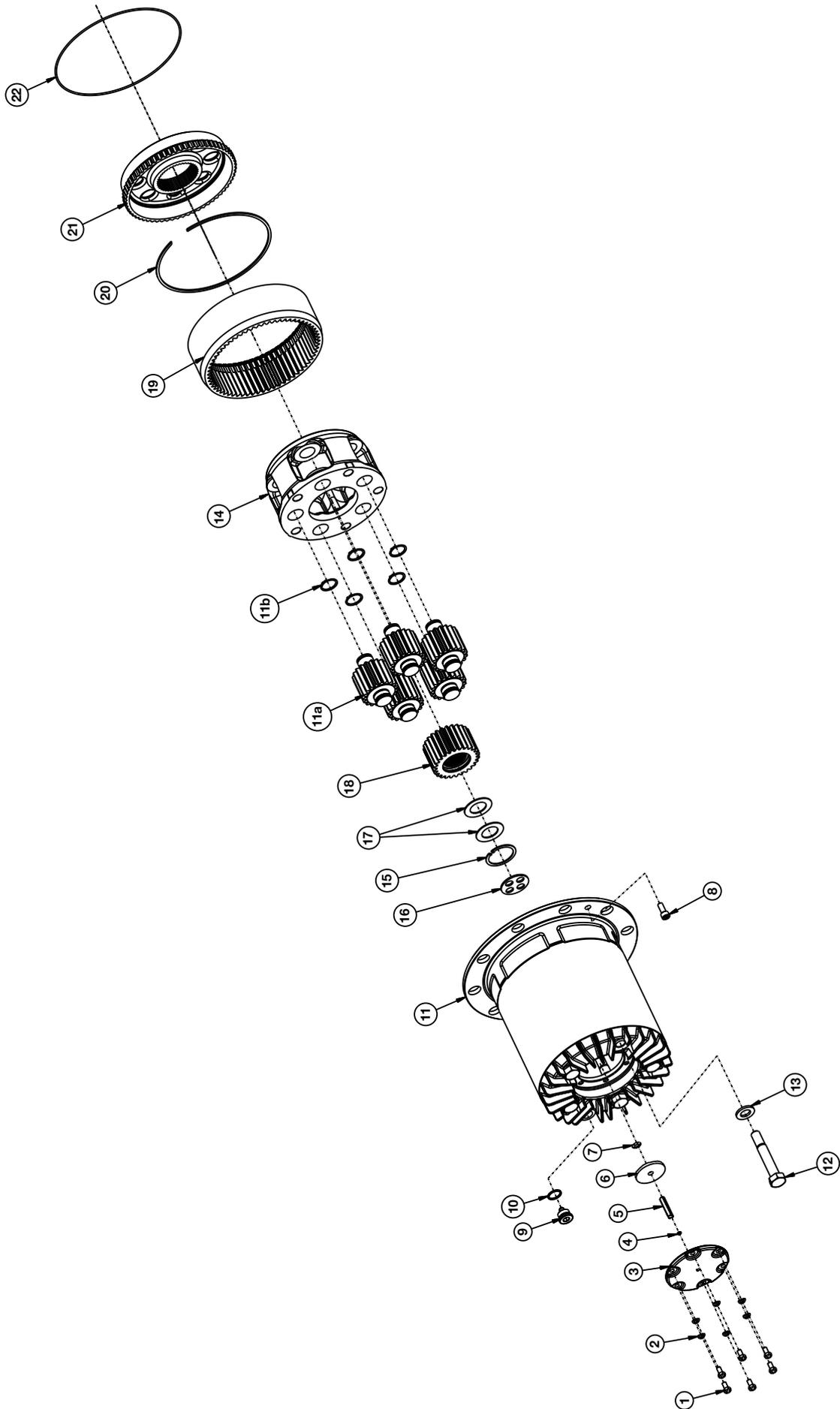

Planetary Case Assembly

Item	Description	Quantity	Part Number	Notes
1	Screw M8x16x1.0	6	41X2084	
2	Washer Flat	6	1229S5687	
3	Cover, Hub Reduction	1	3266Z1924	
4	Washer	AR	955891	
5	Pin Grooved	1	1523115	Use 1523115 or 1523116 based on end play, 52 mm
5	Pin Grooved	1	1523116	Use 1523115 or 1523116 based on end play, 56 mm
6	Magnet Hub Cover P600	1	2297W8733	
7	Retainer	1	967581	
8	Screw Hex Socket (M10x25)	2	41X1668	
9	Plug Drain Magnetic	1	981281	
10	Gasket Copper	1	949329	
11	Planetary Case Assembly	1	A3298S1319	
11a	Kit Planetary	5	E816	
11b	Ring Retaining	5	914463	
12	Screw M18x120x2	5	41X1734	
13	Washer Flat M20x4	5	MWA-520 P	
14	Carrier Planetary Pinion	1	3298T1294	
15	Ring Retaining	1	914532	
16	Washer Thrust	1	1522393	
17	Washer Thrust MTXX-610	2	1673500	
18	Sun Gear	1	3892T5948	
19	Ring Gear	1	1522380	
20	Ring Retaining	1	1522392	
21	Ring Gear Carrier	1	3191997	
22	O Ring Std Viton	1	982108	

Spindle Assembly

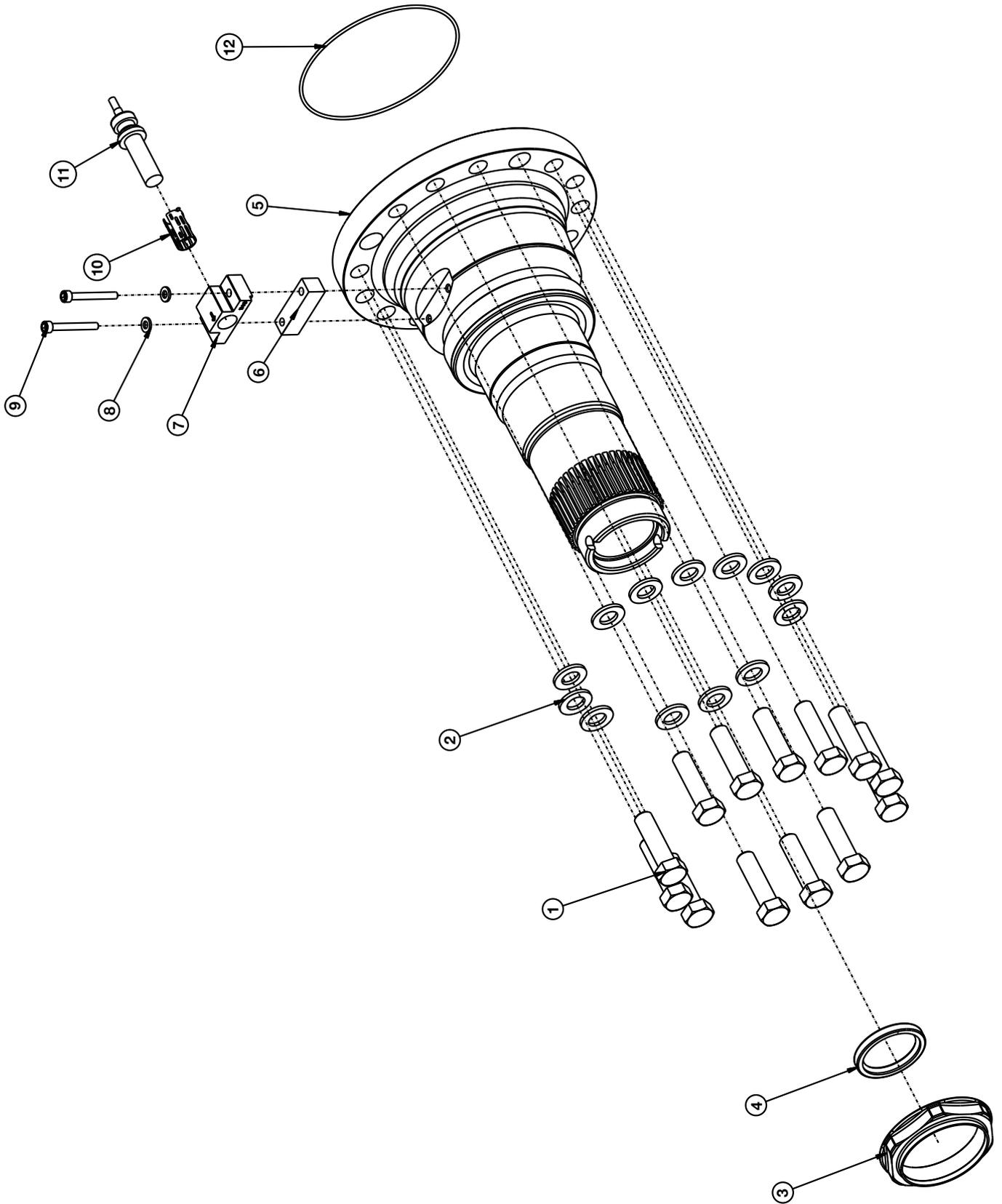

Spindle Assembly

Item	Description	Quantity	Part Number	Notes
1	Screw M16x60x2 GRD10.9	13	MS216060A 2	
2	Washer Flat 16.7mm	13	1229W1557	
3	Wheel Nut	1	1227S1735	
4	Seal Ring	1	1522373	Built before May 2021
4	Seal Ring	1	A1205V2960	Built after May 2021
5	Spindle Assembly	1	3213H2244	
6	Block Sensor Support	1	2297M8931	ABS on Rear Spindle only
7	Block Sensor Holder	1	2255D1148	
8	Flat Washer	2	MWA-506P	
9	Screw	2	SP 2053	
10	Bushing Sensor	1	2237W1531	
11	ABS Sensor	1	A 2237Z1586	
12	O Ring P600	1	5X1371	

Gearsets and Bearing Kits

FRONT CARRIER GEARSETS A4-3200S2411 (XXX)

Gearset - Ratio	Complete Kit Part Number	Gearset Part Number Only	Notes
Gearset - 1.00	E782.M	A43450	Kit includes: gearset, screws, locking plate and nut
Gearset - 1.04	E783.M	1524957	
Gearset - 1.09	E784.M	1524907	
Gearset - 1.19	E785.M	1524908	
Gearset - 1.32	E786.M	1524909	
Gearset - 1.35	E854.M	A43470	
Gearset - 1.56	E787.M	1524910	
Gearset - 1.58	E855.M	A43462	
Gearset - 1.79	E856.M	A43458	
Gearset - 2.08	E788.M	1524911	

REAR CARRIER GEARSETS A3-200W2415(XXX)

Gearset - Ratio	Complete Kit Part Number	Gearset Part Number Only	Notes
Gearset - 1.00 Ratio	E790.M	B43448	Kit includes: gearset, screws, locking plate and nut
Gearset - 1.04 Ratio	E791.M	1524938	
Gearset - 1.09 Ratio	E792.M	1524939	
Gearset - 1.19 Ratio	E793.M	1524940	
Gearset - 1.32 Ratio	E794.M	1524941	
Gearset - 1.35 Ratio	E857.M	A43468	
Gearset - 1.56 Ratio	E795.M	1524942	
Gearset - 1.58 Ratio	E858.M	A43460	
Gearset - 1.79 Ratio	E859.M	A43456	
Gearset - 2.08 Ratio	E797.M	1524943	

FORWARD CARRIER BEARING KIT

Part Number	Component Parts	Description	Quantity
KITAU2610F	1229A5253	Thrust Washer	1
	3266R1682	Cover Pinion	1
	1522345	Needles	324
	1524058	Input Bearing FWD	1
	1524061	Bearing	1
	1524857	Bearing roller	1
	1524964	Bearing Roller	1
	1524985	Bearing Pinion	1
	1524982	Bearing Pinion	1
	181632	Needle Roller Assy	1
	1524881	Needle Roller Assy	1
	A11205L2794	Seal Asssy	1
	1524988	Bearing Roller	1
	1524838	Seal thru Shaft MDXX-610	1

Gearsets and Bearing Kits

REAR CARRIER BEARING KIT

Part Number	Component Parts	Description	Quantity
KITAU2610R	1522345	Needles	140
	1524857	Bearing Roller	1
	1524926	Bearing Pinion	1
	1524964	Bearing Roller	1
	1673537	Bearing Pinion	1
	A11205L2794	Seal Assembly	1



Meritor Heavy Vehicle Systems Australia
50 Calarco Drive
Derrimut, VIC 3026
AUSTRALIA

(03) 8353 6050

meritorpartsexpress.com

CMCVSPB001-P610 SERIES PLANETARY AXLES
PARTS BOOK 04/24
Produced in AUS 04/24
©2024 Cummins Inc.